

WELCOME

to the US Lacrosse Officials Education Program

Hosted by WWLUA

Washington Women's Lacrosse Umpire Association

www.wwlua.org



About US Lacrosse

US Lacrosse was established as the National Governing Body (NGB) for men's and women's lacrosse in 1998.

Our Mission

US Lacrosse is the national governing body of lacrosse. Through responsive and effective leadership, we provide programs and services to inspire participation while protecting the integrity of the sport.

Educating officials is a critical step in making this vision a reality!

We are a membership-based organization
Your membership includes exclusive benefits such as *Lacrosse Magazine*, liability insurance, and much more. It also supports the development of resources for officials like you!

www.uslacrosse.org



WWLUA

Washington Women's Lacrosse Umpire Association

- Website: www.wwlua.org
- Mailing address
 - For submitting forms
- On our website...
 - Game Report
 - Feedback Form
 - Handouts, Links
- Requesting games



Women's Game Committee

Four Guiding Principles:

- Honor the past
- Commit to the core values
- Maintain relevance
- Respect all participants





Professionalism,
Responsibility,
Ethics

Positioning,
Field
Coverage,
Fitness

Safety
Fairness
Fun

Comportment,
Communication,
Teamwork

Knowledge &
Judgment

Game
Management,
Penalty
Administration,
Mechanics



5 Types of Fouls

Professionalism,
Responsibilities,
Ethics

**Knowledge &
Judgment**

Positioning, Field
Coverage, and
Fitness

**Game Management,
Penalty
Administration,
Mechanics**

Comportment,
Communication,
Teamwork

- Major fouls
- Minor fouls
- Goal circle fouls – minor
- Team foul/Restraining
Line/Offside – major
- Misconduct – major

The penalty for fouls is a “free position” where the ball is awarded to the player who is fouled.



Major Fouls

- **Rough play, safety concerns**

Use of the stick or crosse

Body to body

Playing the ball illegally

Positioning

Professionalism,
Responsibilities,
Ethics

**Knowledge &
Judgment**

Positioning, Field
Coverage, and
Fitness

**Game Management,
Penalty
Administration,
Mechanics**

Comportment,
Communication,
Teamwork



The Sphere

Professionalism,
Responsibilities,
Ethics

Knowledge &
Judgment

Positioning, Field
Coverage, and
Fitness

Game Management,
Penalty
Administration,
Mechanics

Comportment,
Communication,
Teamwork

The definition of the **sphere**: an imaginary area of 18cm or 7 inches surrounding the head

Why does the **sphere** exist?

What fouls are considered dangerous to a *player's safety* with respect to the **sphere**?



Obstruction of Free Space to Goal (Shooting Space)

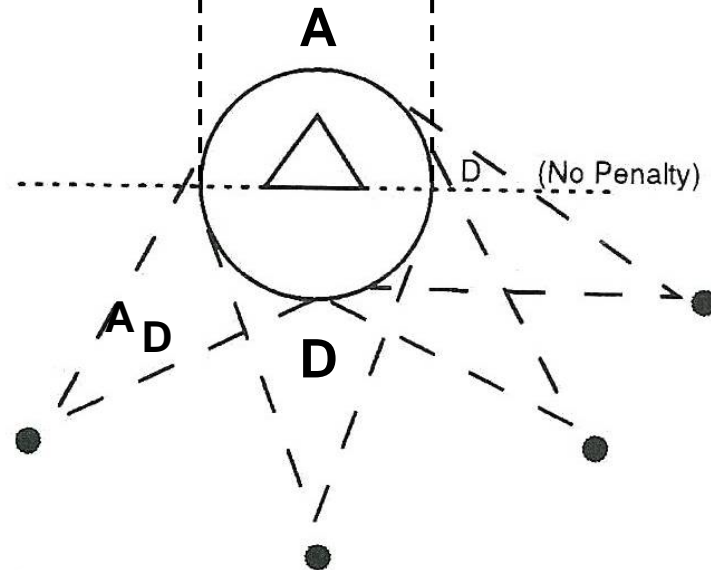

Diagram 8 - Free Space to Goal

Free Space to Goal (FSG)

What is the definition?

FSG and the zone defense

Umpire responsibilities



Professionalism,
Responsibilities,
Ethics

Knowledge &
Judgment

Positioning, Field
Coverage, and
Fitness

Game Management,
Penalty
Administration,
Mechanics

Comportment,
Communication,
Teamwork

Three Second Violation

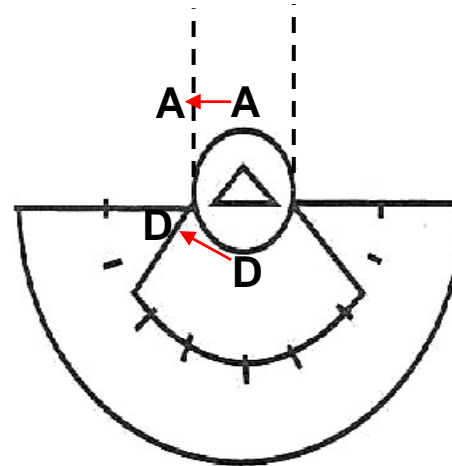

Three Second Violation

What are the parameters?
Making the call



Professionalism,
Responsibilities,
Ethics

Knowledge &
Judgment

Positioning, Field
Coverage, and
Fitness

Game Management,
Penalty
Administration,
Mechanics

Comportment,
Communication,
Teamwork

Rule 7: Penalty Administration

Major Fouls and the CSA

Professionalism,
Responsibilities ,
Ethics

**Knowledge &
Judgment**

Positioning, Field
Coverage, and
Fitness

**Game Management,
Penalty
Administration ,
Mechanics**

Comportment,
Communication,
Teamwork

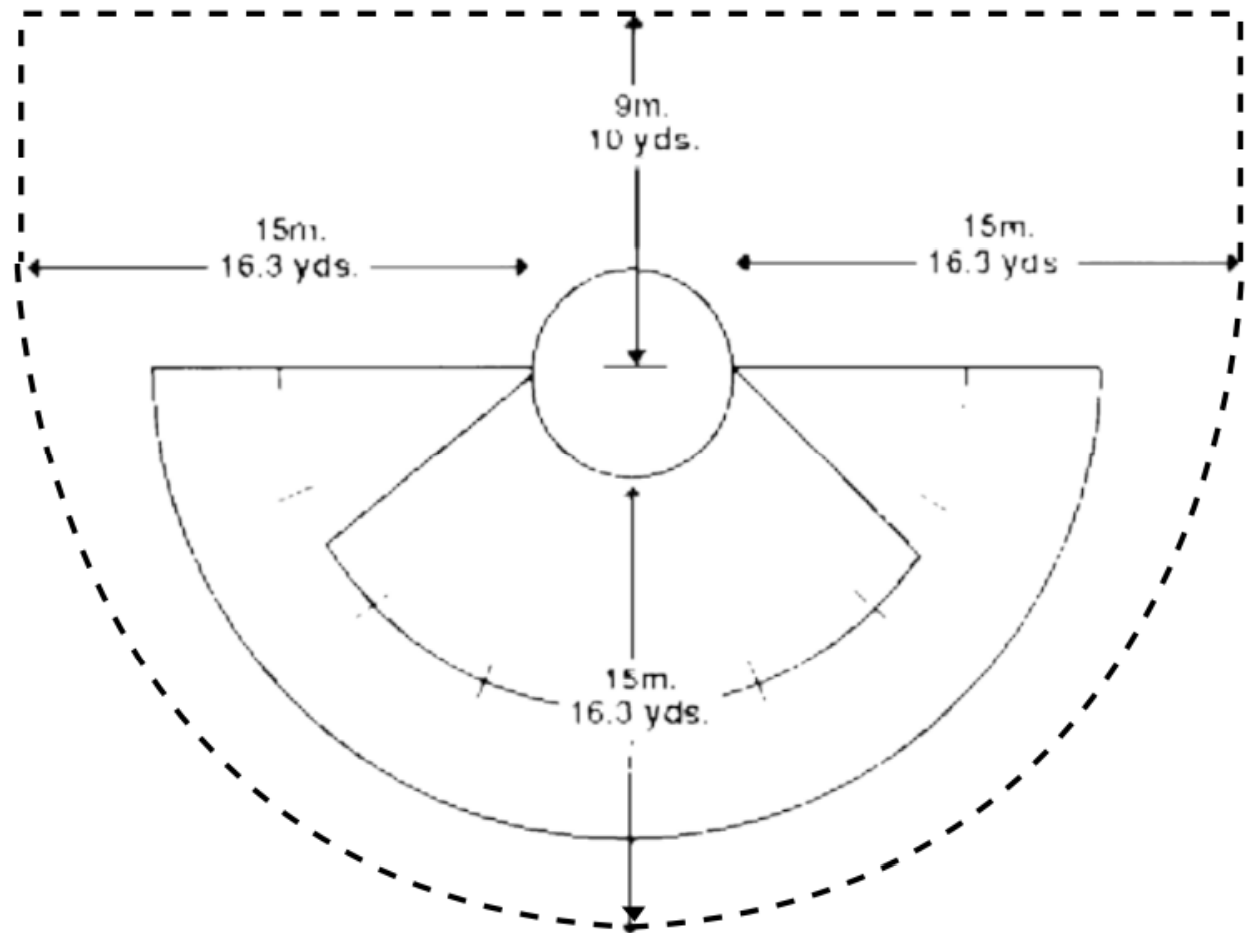

Diagram 6 - Critical Scoring Area

Rule 7: Penalty Administration – Major Fouls

Three areas of the field to consider

1. Outside the CSA

- Free position (Ball) on the spot of the foul
- Offender 4m behind
- Others 4m away

2. Within CSA but outside 8m arc

- Free position (Ball) on the spot of the foul
- Offender 4m behind
- Others 4m away
- Clear the penalty lane

● Designates position of ball

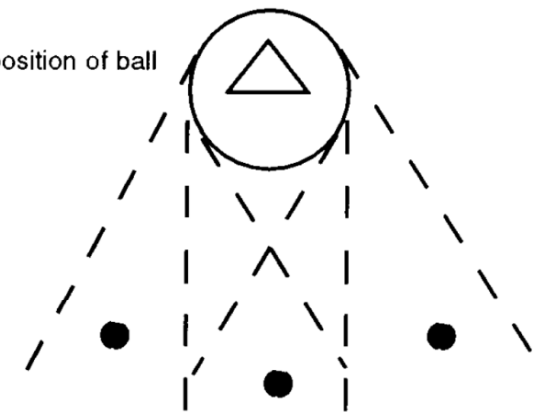

Diagram 9 - Penalty Lane

Professionalism,
Responsibilities,
Ethics

**Knowledge &
Judgment**

Positioning, Field
Coverage, and
Fitness

**Game Management,
Penalty
Administration,
Mechanics**

Comportment,
Communication,
Teamwork

Rule 7: Penalty Administration – Major Fouls

3. Inside the 8m arc

- Free position (Ball) on the closest hash mark on the 8m arc*
- Offender 4m behind on the 12m fan
- Others 4m away
- Clear the 8m arc and the penalty lane (if needed)

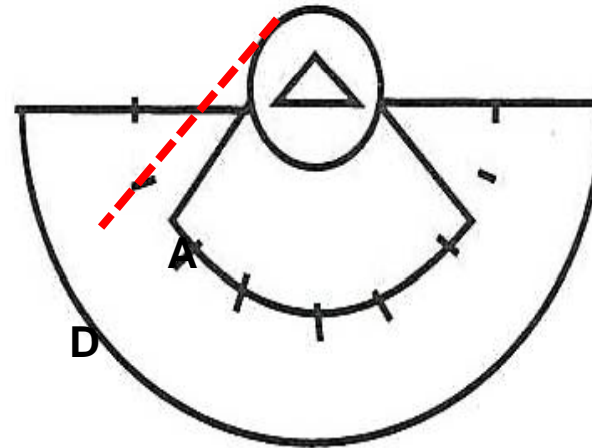

* No free position may be taken closer than 8m to the goal circle



Professionalism,
Responsibilities,
Ethics

**Knowledge &
Judgment**

Positioning, Field
Coverage, and
Fitness

**Game Management,
Penalty
Administration,
Mechanics**

Comportment,
Communication,
Teamwork

Rule 7: Penalty Administration – Slow Whistle/Yellow Flag

Professionalism,
Responsibilities ,
Ethics

**Knowledge &
Judgment**

Positioning, Field
Coverage, and
Fitness

**Game Management,
Penalty
Administration ,
Mechanics**

Comportment,
Communication,
Teamwork

A **“slow whistle”** is a held whistle, indicated by raising the yellow flag because all three of these criteria occur:

- Major foul committed by the defense and attack maintains possession
- The ball is in the CSA
- Attack is on a scoring play



Professionalism,
Responsibilities,
Ethics

**Knowledge &
Judgment**

Positioning, Field
Coverage, and
Fitness

**Game Management,
Penalty
Administration,
Mechanics**

Comportment,
Communication,
Teamwork

Rule 7: Penalty Administration – Slow Whistle/Yellow Flag

A **“scoring play”** is a continuous effort by the attacking team to move the ball toward the goal and to complete a shot on goal.

The scoring play is over when

- A shot is taken;
- The attacking team loses possession of the ball;
- The attacking team passes or carries the ball behind the level of the goal line and stops the continuous attempt to score;
- The attacking team stops the continuous attempt to score or the player with the ball is forced by the defense to lose her forward momentum;
- The attacking team fouls.

Minor Fouls

Professionalism,
Responsibilities ,
Ethics

**Knowledge &
Judgment**

Positioning, Field
Coverage, and
Fitness

**Game Management,
Penalty
Administration ,
Mechanics**

Comportment,
Communication,
Teamwork

- **Skills and Rules**
- **Rule 6, Section 2**

Illegal equipment or uniform

Procedural errors

Misplays vs. legal plays



Rule 7: Penalty Administration – Minor Fouls

Two areas of the field to consider

1. Outside the 12m fan

- Free position (Ball) on the spot of the foul
- Offender 4m away
- Others 4m away

2. Within the 12m fan

- Free position (Ball) on the 12m fan closest to the spot of the foul
- Offender 4m away
- Others 4m away
- Umpire says “Indirect”
- Ball must be **played** before a shot is taken

“Played”: ball leaves her crosse and is touched by another player or she is checked corss-to-crosse by an opposing player (ball does not have to be dislodged).

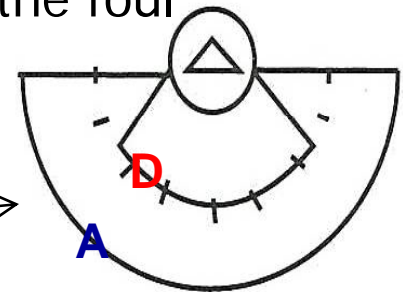

Professionalism,
Responsibilities,
Ethics

**Knowledge &
Judgment**

Positioning, Field
Coverage, and
Fitness

**Game Management,
Penalty
Administration,
Mechanics**

Comportment,
Communication,
Teamwork

2011 USL New Rules

- USL video



Goal Circle Fouls

- **Rule 6, Sections 3-6**
Goal circle line – who's is it?
Minor fouls

Professionalism,
Responsibilities ,
Ethics

**Knowledge &
Judgment**

Positioning, Field
Coverage, and
Fitness

**Game Management,
Penalty
Administration ,
Mechanics**

Comportment,
Communication,
Teamwork



Penalty Administration: Goal Circle Fouls

Professionalism,
Responsibilities,
Ethics

**Knowledge &
Judgment**

Positioning, Field
Coverage, and
Fitness

**Game Management,
Penalty
Administration,
Mechanics**

Comportment,
Communication,
Teamwork

- **Attack fouls**
 - Ball to goalkeeper in goal circle
 - Offender and Others 4m away
- **Defense or goalkeeper fouls**
 - Ball to attack at corner of 12m (on goal line extended) – “indirect”
 - Offender 4m away on goal line extended (except goalie can stay in goal circle – no one else is moved)
 - Others 4m away



Goal Circle Foul: Illegal Deputy

Professionalism,
Responsibilities ,
Ethics

Knowledge &
Judgment

Positioning, Field
Coverage, and
Fitness

Game Management,
Penalty
Administration ,
Mechanics

Comportment,
Communication,
Teamwork

- What is a deputy?
- **Major Foul!**
- **Penalty Administration**
 - Attack gets ball at center hash on 8m arc
 - Illegal deputy 4m behind (on 12m fan)
 - Others 4m away, clear the 8m arc
 - Goalkeeper may **not** clear into the goal circle



Team Fouls/Offside (Major foul)

- **Rule 6, Section 7**
- **Penalty Administration**
 - Offside by the attack
 - Offside by the defense
 - In the CSA and above goal line extended
 - Outside of the CSA or below goal line extended
 - Offside by both teams
 - Correct off-sides – administer a throw
 - Set-up
 - Correct the off-sides
 - Give ball to non-offending team
 - Defender 4m behind (major foul)



Professionalism,
Responsibilities,
Ethics

**Knowledge &
Judgment**

Positioning, Field
Coverage, and
Fitness

**Game Management,
Penalty
Administration,
Mechanics**

Comportment,
Communication,
Teamwork

Team Fouls/Offside (Major foul)

- **Offside by Attack**

- Put attack A1 player closest to RL on-side at the center of the field (width)
- Give ball to defense D1 player closest to RL from below the RL, position player 4m ahead of attack A1

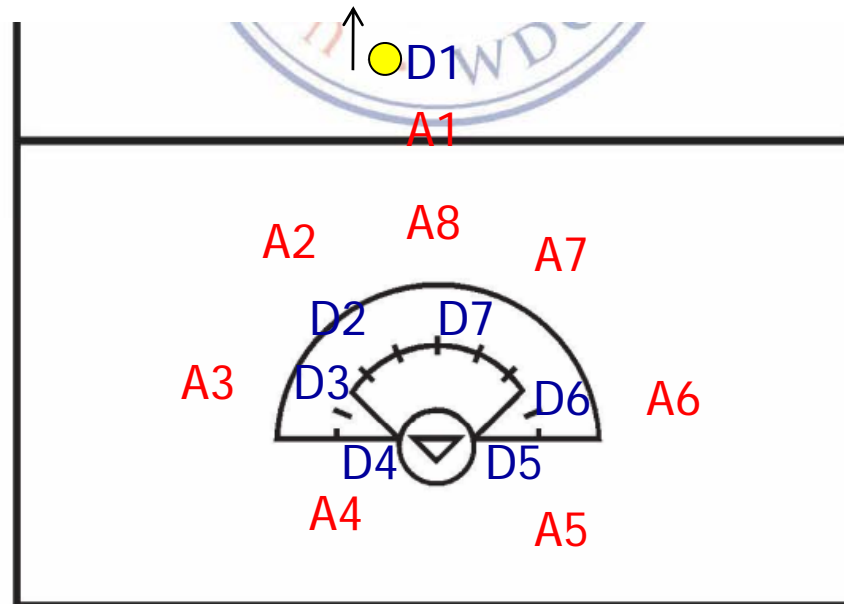

Professionalism,
Responsibilities,
Ethics

**Knowledge &
Judgment**

Positioning, Field
Coverage, and
Fitness

**Game Management,
Penalty
Administration,
Mechanics**

Comportment,
Communication,
Teamwork

Team Fouls/Offside (Major foul)

• Offside by Defense

- Put defense D1 player closest to RL on-side at the center of the field (width)
- If the ball is in the CSA and above the goal line extended, give ball to attack A1 player closest to top of 12m fan at the center top of the 12m fan
- Put closest defender D8 4m behind ball & clear the penalty lane

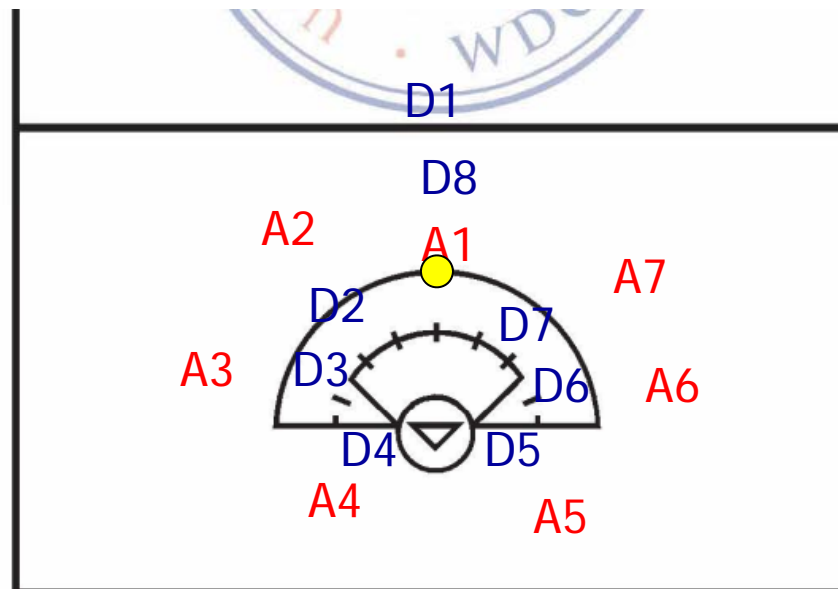

If the ball is outside the CSA or below the goal line extended, attack is given the ball on the spot of the ball and closest defender is placed 4m behind. (not within 8m of GC)

Professionalism,
Responsibilities,
Ethics

Knowledge &
Judgment

Positioning, Field
Coverage, and
Fitness

Game Management,
Penalty
Administration,
Mechanics

Comportment,
Communication,
Teamwork

Rule 6: Major Foul – Misconduct

Professionalism,
Responsibilities,
Ethics

**Knowledge &
Judgment**

Positioning, Field
Coverage, and
Fitness

**Game Management,
Penalty
Administration,
Mechanics**

Comportment,
Communication,
Teamwork

- **Rule 6, Section 8**

Misconduct by:

defense

offense/attack

both teams

sideline personnel and/or fans

Use of cards

A timeout must be taken by
the Umpire to administer cards.



Rule 7: Use of Cards

When to use the cards

Carding Procedures

Delay of game

Yellow card

Warning

Suspension

Red card – ejection

Coaches and team personnel

Professionalism,
Responsibilities ,
Ethics

**Knowledge &
Judgment**

Positioning, Field
Coverage, and
Fitness

**Game Management,
Penalty
Administration ,
Mechanics**

Comportment,
Communication,
Teamwork



Signals

Professionalism,
Responsibilities ,
Ethics

**Knowledge &
Judgment**

Positioning, Field
Coverage, and
Fitness

**Game Management,
Penalty
Administration ,
Mechanics**

Comportment,
Communication,
Teamwork

Mechanics

Thought process

Advantage

B.O.O.

Ball – Offender - Others



Seven Steps

Professionalism,
Responsibilities,
Ethics

**Knowledge &
Judgment**

Positioning, Field
Coverage, and
Fitness

**Game Management,
Penalty
Administration,
Mechanics**

Comportment,
Communication,
Teamwork

1. Whistle
2. Foul signal
3. Direction
4. B.O.O
5. Reposition self
6. Quick look
7. Restart play



Youth Rules

Professionalism,
Responsibilities ,
Ethics

**Knowledge &
Judgment**

Positioning, Field
Coverage, and
Fitness

**Game Management,
Penalty
Administration ,
Mechanics**

Comportment,
Communication,
Teamwork

Levels FC, A, B, C

WSLA Youth:

U15 (7/8): Level A

U13 (5/6): Level B

U11 (3/4): Level C



Responsibilities

Safety

Fun

Fairness



Professionalism,
Responsibilities,
Ethics

Knowledge &
Judgment

Positioning, Field
Coverage, and
Fitness

Game Management,
Penalty
Administration,
Mechanics

Comportment,
Communication,
Teamwork

Responsibilities

Annual Requirements

- Remain in “Good Standing”

Proper Umpiring Equipment

- Starter kit (whistle, flag, cards)
- ¾ inch black & white striped shirt
- Black pants, shorts, or kilt
- Mostly black accessories (visor, hat, shoes, bag)

The “Business” of Officiating

- Be professional; this is a job
- Mileage/ferry reimbursements
- Taxes (if you earn >\$600, you’ll receive a 1099 form from WWLUA)



Professionalism,
Responsibilities,
Ethics

Knowledge &
Judgment

Positioning, Field
Coverage, and
Fitness

Game Management,
Penalty
Administration,
Mechanics

Comportment,
Communication,
Teamwork

Professionalism,
Responsibilities,
Ethics

Knowledge &
Judgment

Positioning, Field
Coverage, and
Fitness

Game Management,
Penalty
Administration,
Mechanics

Comportment,
Communication,
Teamwork

“Good Standing” Checklist

- Complete US Lacrosse registration online. Become a Member of USL!
- Complete Local Board registration forms ~~and pay dues.~~
 - WWLUA Umpire Registration & Agreement Form
 - IRS W-9 Form
 - Signed USL Membership Form (We need a hard-copy with signature for insurance. This will not get you a USL membership.)
 - Parent/School Authorization Form (if under 18 y.o.)
- ~~Complete state registration, if applicable.~~
- Attend a rules interpretation meeting.
- Pass the US Lacrosse rules test **online** after an on paper practice testing session at home and/or with a group **Due date = March 1, 2011.**
- Pass the practical field test (Rating session) **Earn** a rating.
- Field Test date and location: **TBD.** Check wwlua.org in Jan 2011
- ~~Send availability to local assignor~~
You will request games online at Sportability.com for WSLA & NWWLA!
- Additional Local requirements:
 - Fill out **Game Reports** after every game (wwlua.org) (new for 2011)



Ethics

To maintain professionalism and responsibility, it is important to follow ethical guidelines. When accepting assignments, be fair to the teams and yourself:

- Do not officiate a game in which a family member is participating
- Junior umpires must officiate two levels below their age group
- Behavior before, during, and after game reflects on you and your officiating team
- If problems with another umpire, contact: Maggie (chair@wwlua.org) or Jeff (secretary@wwlua.org)
- If problems with parents, fans and/or coach, contact: Maggie (chair@wwlua.org) or Jeff (secretary@wwlua.org)



Professionalism,
Responsibilities,
Ethics

Knowledge &
Judgment

Positioning, Field
Coverage, and
Fitness

Game Management,
Penalty
Administration,
Mechanics

Comportment,
Communication,
Teamwork

Professionalism

Professionalism,
Responsibilities,
Ethics

Knowledge &
Judgment

Positioning, Field
Coverage, and
Fitness

Game Management,
Penalty
Administration,
Mechanics

Comportment,
Communication,
Teamwork

Be prepared:

- Review the rules, penalty administration, etc.
- Confirm game location, time, and partner **on Sportability.com**
- Remember your role as an official
- Don't be late!
- Dress neatly



Professionalism,
Responsibilities,
Ethics

Knowledge &
Judgment

Positioning, Field
Coverage, and
Fitness

Game Management,
Penalty
Administration,
Mechanics

Comportment,
Communication,
Teamwork

Umpire Ratings

- New Umpires can **earn** a 1 yr rating
 - Junior Umpire (if under 18 y.o.)
 - Youth Umpire (adult, certified to umpire only Youth level games)
 - Apprentice Umpire (adult, certified to umpire all games: Youth, HS, club)
- Returning adult umpires can **earn** higher ratings that may be for >1 yr
 - Local Umpire (1-3 yrs)
 - District Umpire (1-3 yrs)
 - National Umpire (1-4 yrs)



Rule 1: The Playing Area and Goals

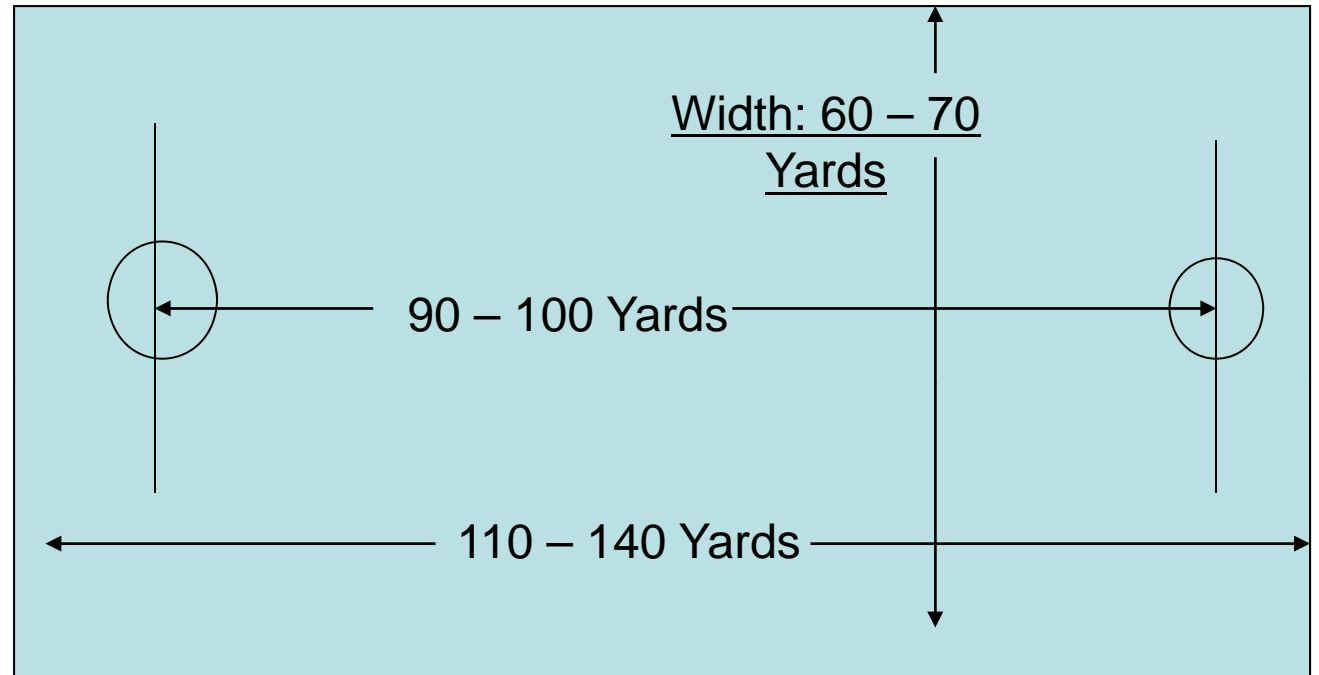

Professionalism,
Responsibilities,
Ethics

**Knowledge &
Judgment**

Positioning, Field
Coverage, and
Fitness

Game Management,
Penalty
Administration,
Mechanics

Comportment,
Communication,
Teamwork

Youth field dimensions

FC & A: USL regulation size

B: 90 yds btwn goal lines; 10 yds behind goal; 50 yds wide

C: 50 yds btwn goal lines; 10 yds behind goal; 25 yds wide



The Playing Field

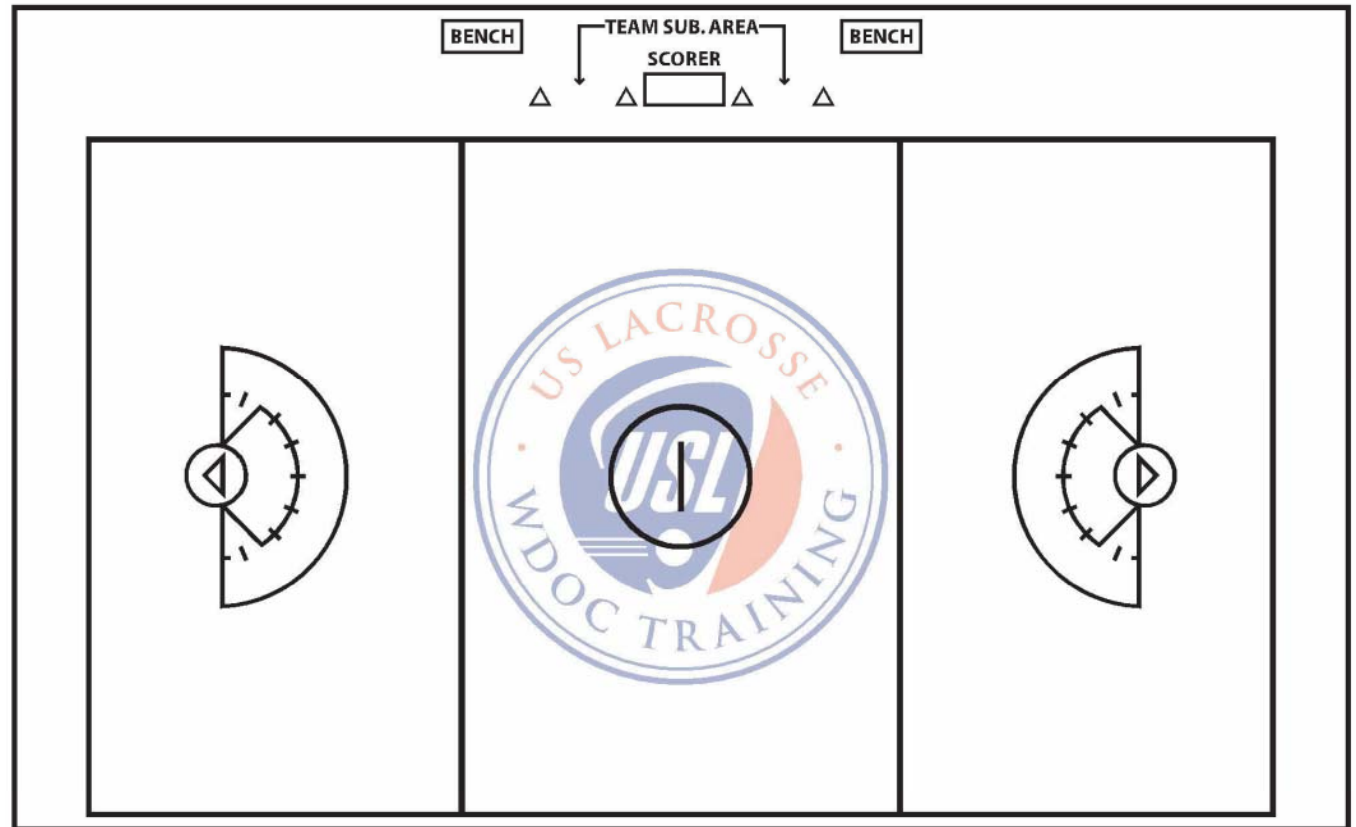

Professionalism,
Responsibilities,
Ethics

**Knowledge &
Judgment**

Positioning, Field
Coverage, and
Fitness

Game Management,
Penalty
Administration,
Mechanics

Comportment,
Communication,
Teamwork

Field Lines for Youth:

FC, A, B: regulation lines

C: goal lines, goal circles, 8m arc, center line



Rule 2: Equipment & Uniforms

Professionalism,
Responsibilities,
Ethics

Knowledge &
Judgment

Positioning, Field
Coverage, and
Fitness

Game Management,
Penalty
Administration,
Mechanics

Comportment,
Communication,
Teamwork

Goals →



Youth Rules:

FC, A: regulation stick

B: regulation or modified stick

C: regulation, modified, or mesh stick



Stick Check

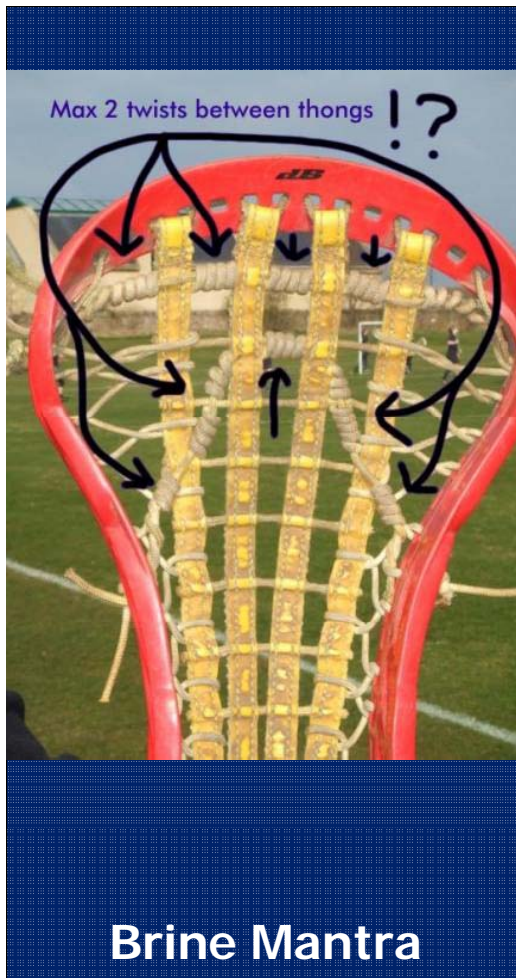

Brine Mantra

Illegal



Legal



1. Take the stick from the player
2. Look over the player
 - Proper uniform and undergarments
 - No jewelry (ears, eyebrows, nose, neck, ankles)
 - Goggles + colored mouthguard
3. Look at the face of the stick
 - 4-5 thongs (none woven back up)
 - Maximum of 2 twists between thongs
4. Look at the side of the stick
 - Proper stringing?
5. Drop the ball in, roll it around, **let go**, hold stick up to your eye level and check pocket



Rule 3: Game Personnel

Professionalism,
Responsibilities,
Ethics

**Knowledge &
Judgment**

Positioning, Field
Coverage, and
Fitness

Game Management,
Penalty
Administration,
Mechanics

Comportment,
Communication,
Teamwork

Teams

Coaches

Umpire

Game administrator

Team captain

Official scorer

Official timer



Pregame

Professionalism,
Responsibilities,
Ethics

**Knowledge &
Judgment**

Positioning, Field
Coverage, and
Fitness

Game Management,
Penalty
Administration,
Mechanics

Comportment,
Communication,
Teamwork

Attire and equipment

Talk with partner

Meet coaches with partner

Walk the field

Captains' meeting

Talk with Coaches

Stick check

Sideline manager (Youth)



Rule 4: Time Factors and Scoring

Professionalism,
Responsibilities,
Ethics

**Knowledge &
Judgment**

Positioning, Field
Coverage, and
Fitness

**Game Management,
Penalty
Administration,
Mechanics**

Comportment,
Communication,
Teamwork

- Duration of play
 - High school: 25 min/half stopped clock
 - Levels FC, A, B: 25 min/half running clock
 - Level C: 20 min/half running clock
- Time outs
- Suspended or interrupted games
- Overtime procedures
- Scoring



Rule 5: Play of the Game

Draw

12 players on the field – exceptions

Illegal draw

Stand

Restraining Line

Out of Bounds

Sideline

Endline

Professionalism,
Responsibilities ,
Ethics

**Knowledge &
Judgment**

Positioning, Field
Coverage, and
Fitness

**Game Management,
Penalty
Administration ,
Mechanics**

Comportment,
Communication,
Teamwork



Rule 5: Play of the Game

Draw

- “toe the line” (not on the line!)
- Sticks are back-to-back with right side towards ground (players push w/ right or pull w/ left hand)
- Sticks must be entirely within the vertical plane of the center line
- Umpire places ball between sticks
- Players must be motionless after the umpire takes her hands away (but may turn their heads)
- Umpire says “Ready”, backs out of circle, and whistles
- A legal draw:
 - Sticks must move UP and AWAY
 - Ball must go above the heads of the 2 players
- Illegal draw = minor foul; offender 45° to the front
 - Can’t determine why it was illegal? Stop clock (unless it is a “running” clock) and set up a re-draw



Rule 5: Play of the Game

Professionalism,
Responsibilities ,
Ethics

**Knowledge &
Judgment**

Positioning, Field
Coverage, and
Fitness

**Game Management,
Penalty
Administration ,
Mechanics**

Comportment,
Communication,
Teamwork

Goal Circle Rules

Throw

Substitution

Accidents, Injuries



Two-Person Positioning

Both umpires perform "lead" and "trail" position duties

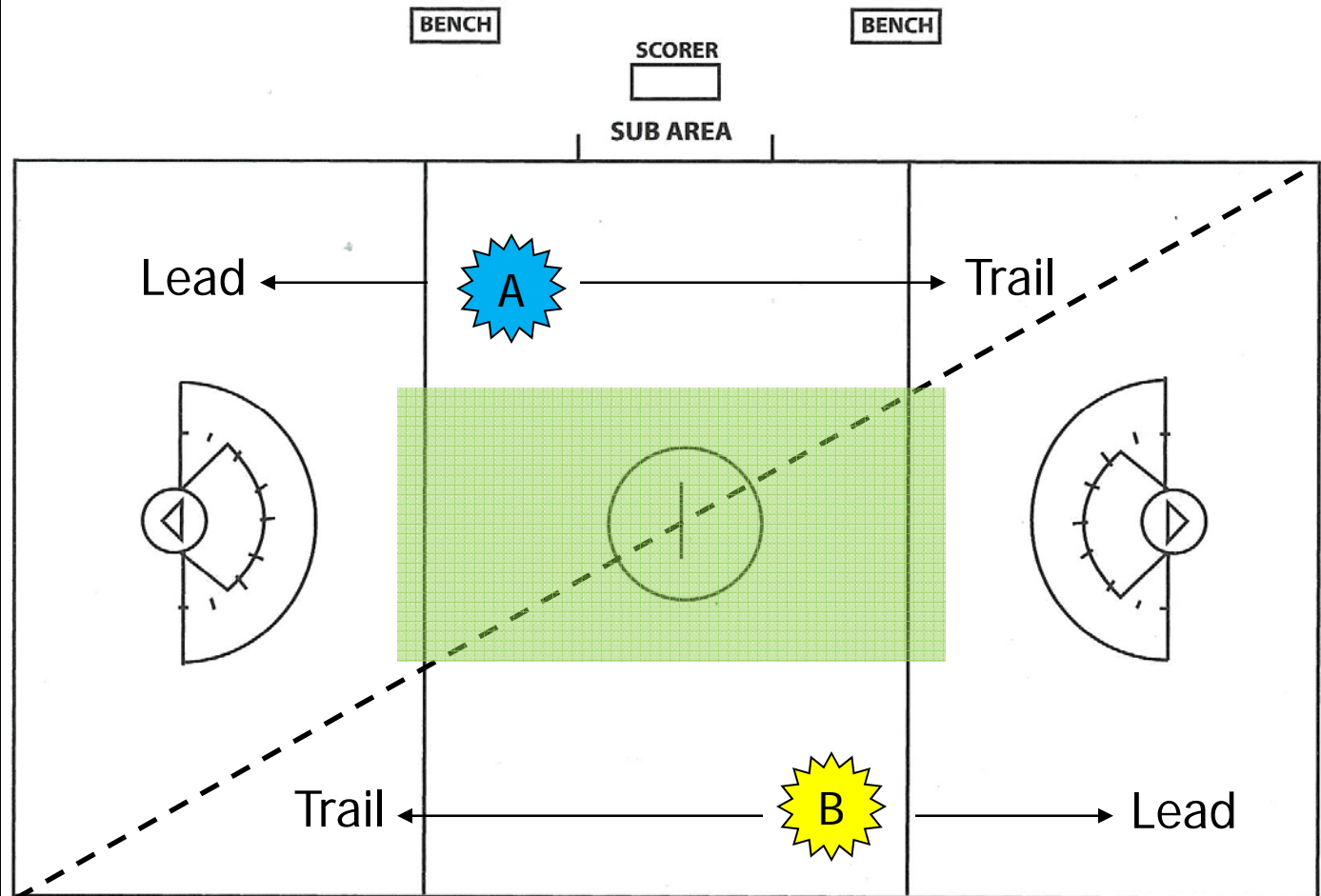

Professionalism,
Responsibilities,
Ethics

Knowledge &
Judgment

Positioning, Field
Coverage, and
Fitness

Game Management,
Penalty
Administration,
Mechanics

Comportment,
Communication,
Teamwork

Two-Person Positioning: Lead

Professionalism,
Responsibilities,
Ethics

Knowledge &
Judgment

Positioning, Field
Coverage, and
Fitness

Game Management,
Penalty
Administration,
Mechanics

Comportment,
Communication,
Teamwork

Moves to the right

Boundaries and endline

Stay ahead of play – why?

Ball in CSA – responsibilities

Tangent and quadrants

FSG and three seconds

Restart play in CSA, signals goal



Two-Person Positioning: Trail

Professionalism,
Responsibilities,
Ethics

Knowledge &
Judgment

**Positioning, Field
Coverage, and
Fitness**

**Game Management,
Penalty
Administration,
Mechanics**

Comportment,
Communication,
Teamwork

Follows play downfield

Boundaries and endline

Monitors Restraining Line

“Field conscious”-watch overall picture

Stay engaged with play

Moves laterally below Restraining Line – why?

Watches for obstruction of FSG

Three seconds, dangerous follow through

Off-ball fouls – picks, illegal detaining



Two-Person Positioning: The Draw

Responsibilities

- To start the game
- After a goal
- Illegal draw
 - Including violations of center circle and Restraining Line



Professionalism,
Responsibilities,
Ethics

Knowledge &
Judgment

Positioning, Field
Coverage, and
Fitness

Game Management,
Penalty
Administration,
Mechanics

Comportment,
Communication,
Teamwork

Two-Person Positioning: Transition

Professionalism,
Responsibilities,
Ethics

Knowledge &
Judgment

Positioning, Field
Coverage, and
Fitness

Game Management,
Penalty
Administration,
Mechanics

Comportment,
Communication,
Teamwork

Stay wide and in front – why?

Shared responsibilities

Angle – who has the best one?

Work together and support one
another

Trust your partner

Keep ahead and anticipate



Umpiring the Goal Circle: Quadrants

Professionalism,
Responsibilities,
Ethics

Knowledge &
Judgment

Positioning, Field
Coverage, and
Fitness

Game Management,
Penalty
Administration,
Mechanics

Comportment,
Communication,
Teamwork

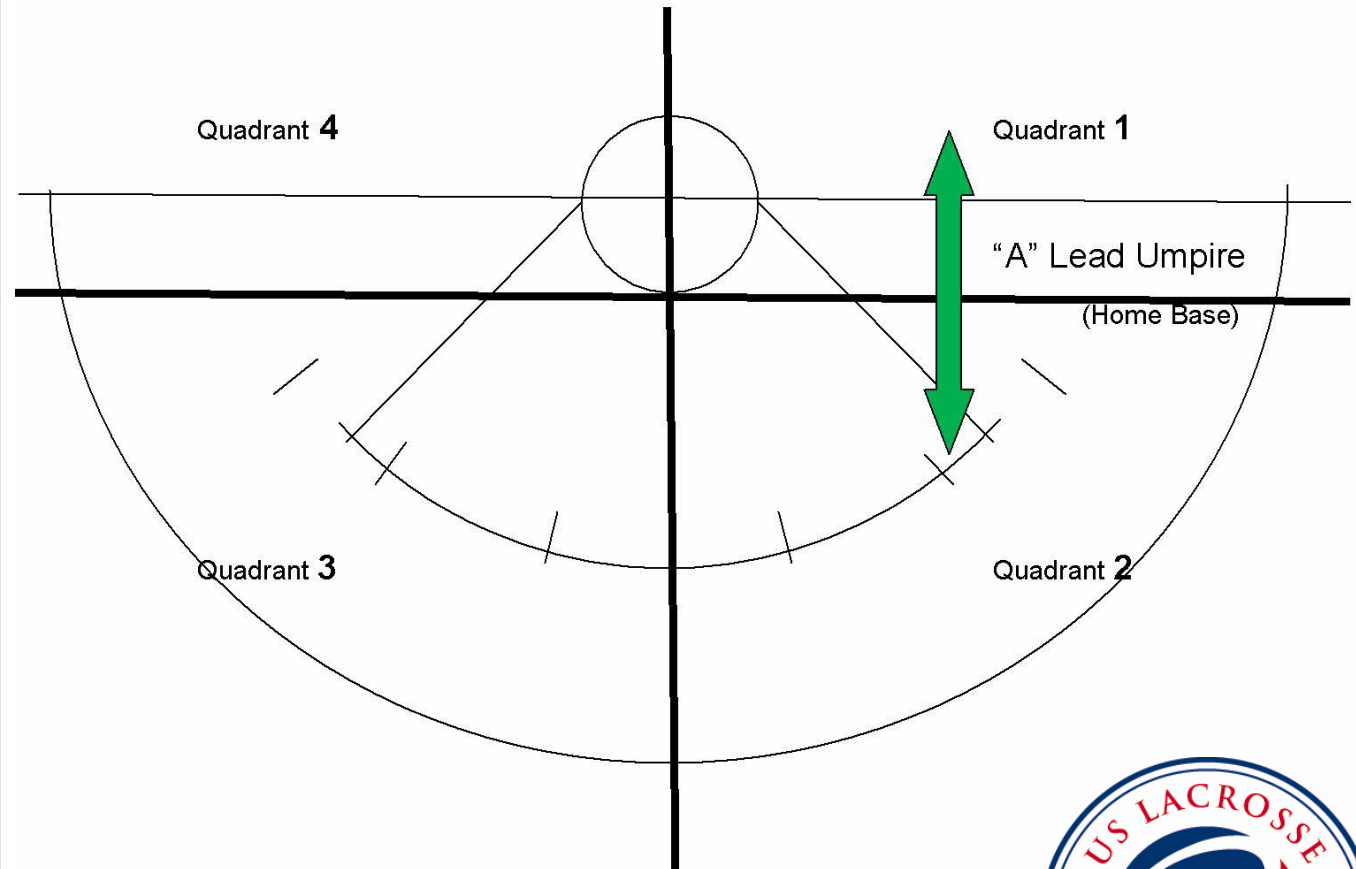

Umpiring the Goal Circle: Quadrants & Tangents

Professionalism,
Responsibilities,
Ethics

Knowledge &
Judgment

Positioning, Field
Coverage, and
Fitness

Game Management,
Penalty
Administration,
Mechanics

Comportment,
Communication,
Teamwork

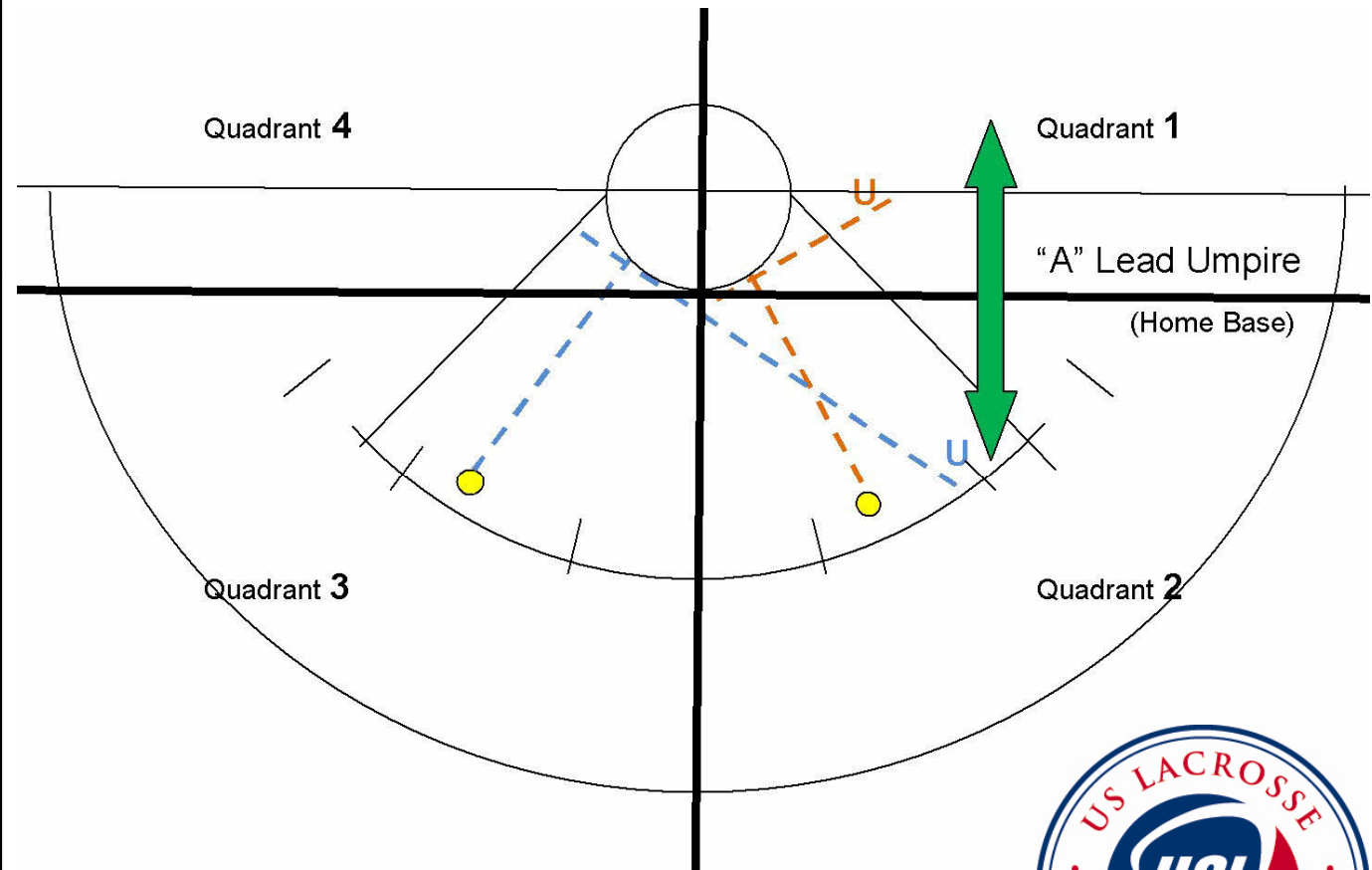

Umpiring the Goal Circle: Quadrants & Tangents

Professionalism,
Responsibilities,
Ethics

Knowledge &
Judgment

Positioning, Field
Coverage, and
Fitness

Game Management,
Penalty
Administration,
Mechanics

Comportment,
Communication,
Teamwork

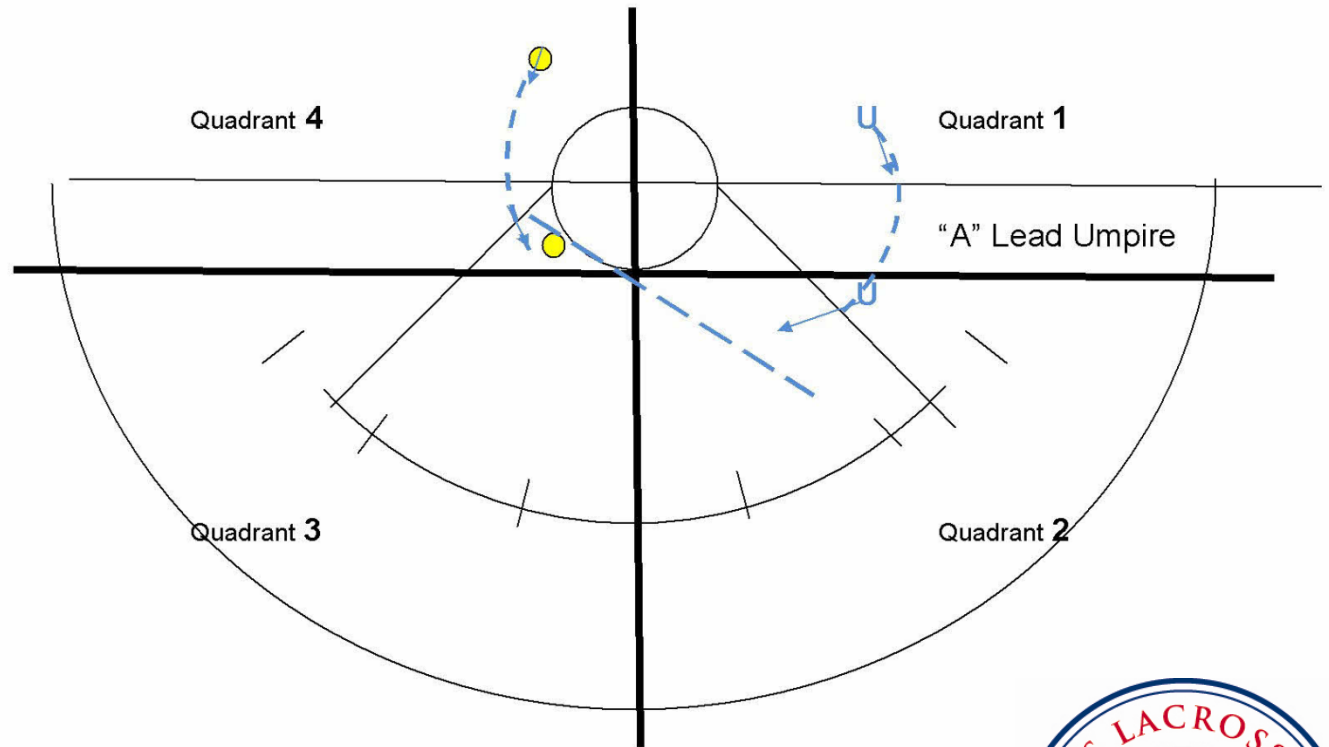

Umpiring the Goal Circle: Quadrants & Tangents

Professionalism,
Responsibilities,
Ethics

Knowledge &
Judgment

Positioning, Field
Coverage, and
Fitness

Game Management,
Penalty
Administration,
Mechanics

Comportment,
Communication,
Teamwork

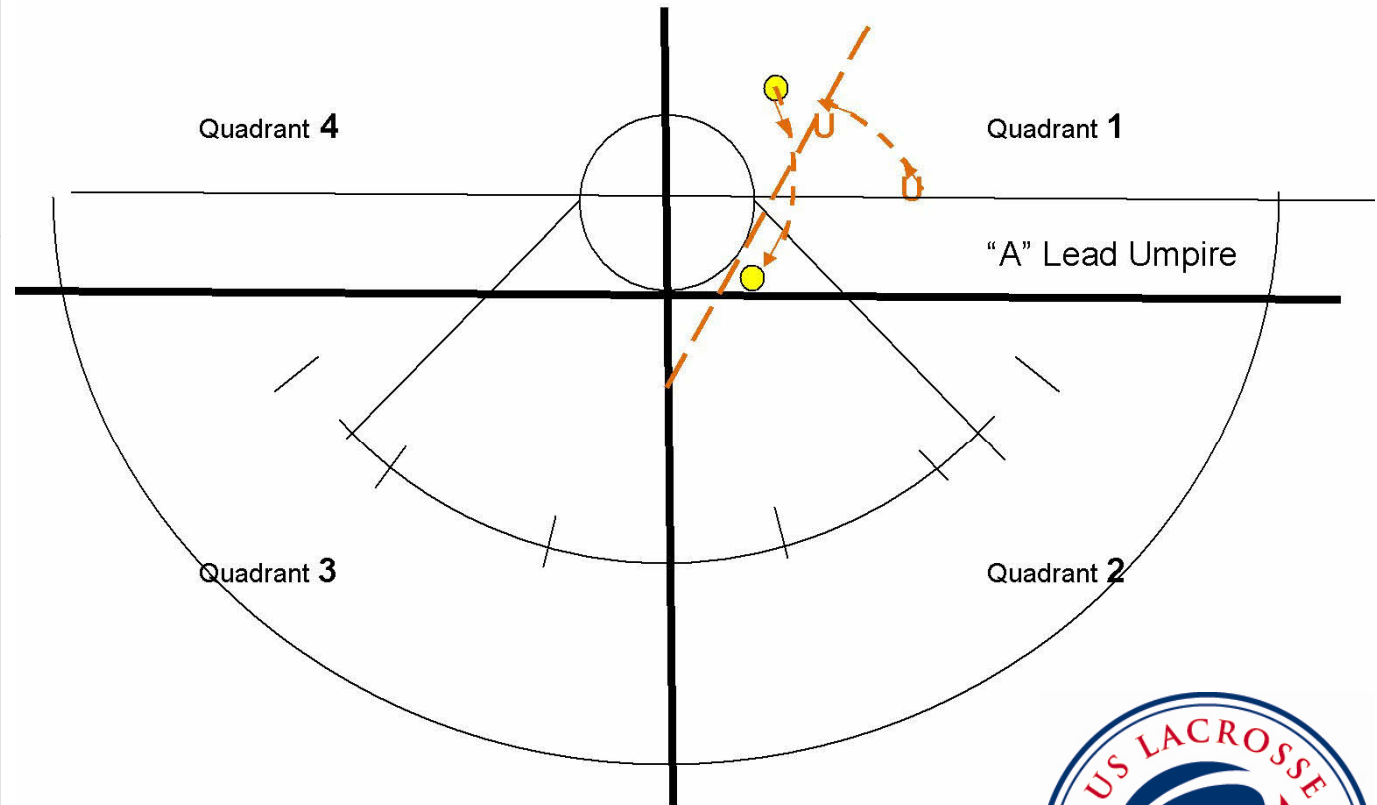

Positioning: Tangent Near Approach

T- Shooting Space, Dangerous Follow Through, Dangerous Propel (also keeping 3 seconds, off-ball fouls in mind). Ready to re-adjust as play dictates.

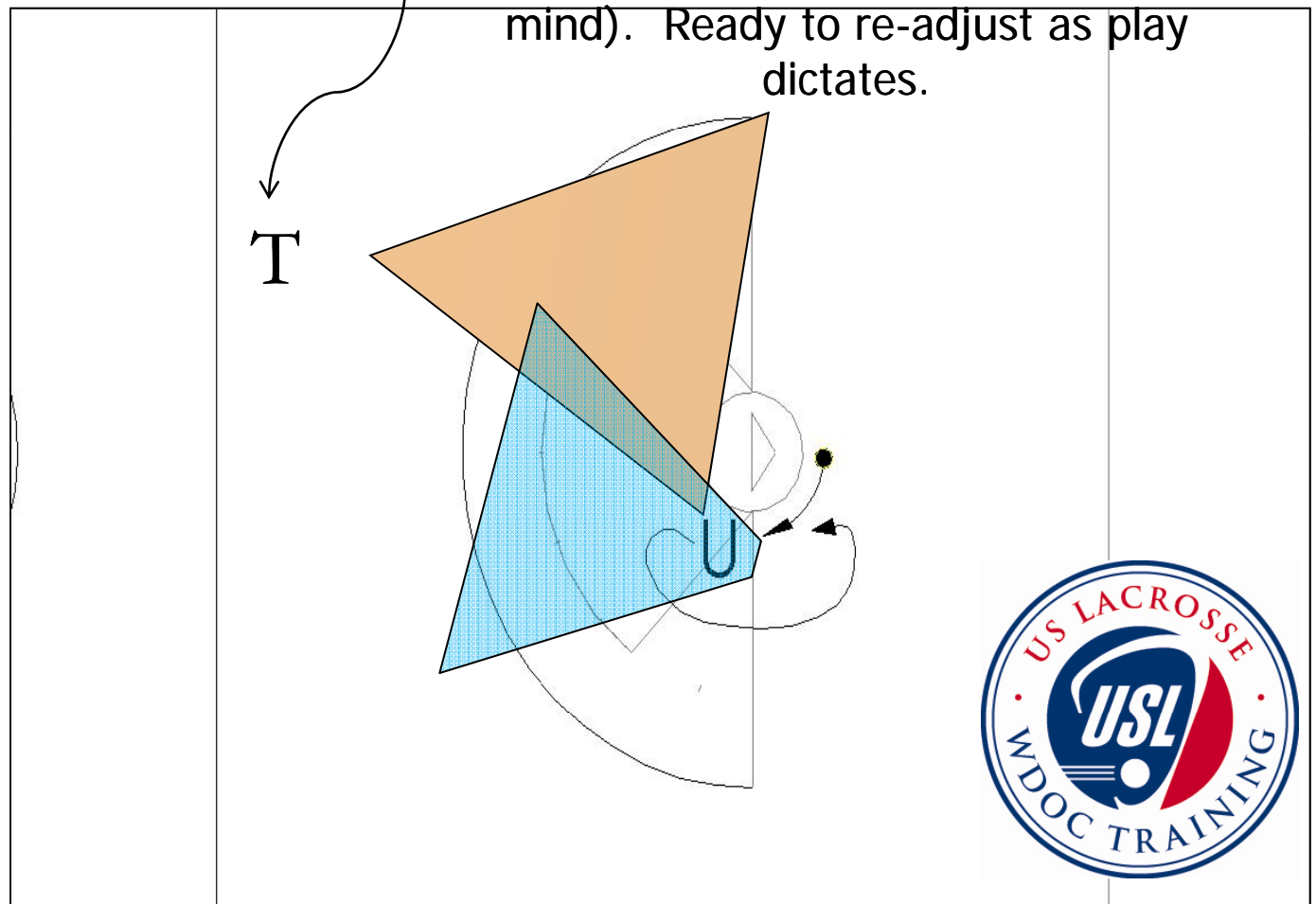

Professionalism,
Responsibilities,
Ethics

Knowledge &
Judgment

Positioning, Field
Coverage, and
Fitness

Game Management,
Penalty
Administration,
Mechanics

Comportment,
Communication,
Teamwork

Positioning: Tangent Mid Approach

Professionalism,
Responsibilities ,
Ethics

Knowledge &
Judgment

Positioning, Field
Coverage, and
Fitness

Game Management,
Penalty
Administration ,
Mechanics

Comportment,
Communication,
Teamwork

T – Shooting Space,
Dangerous Follow Through,
Dangerous Propel (also
keeping 3 seconds, off-ball
fouls in mind)

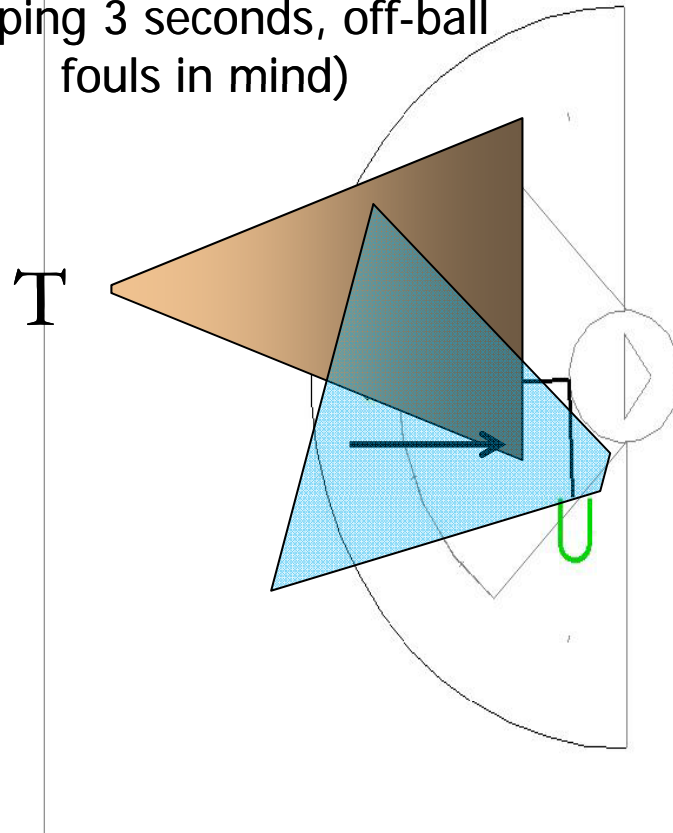

Positioning: Tangent Far Movement

Professionalism,
Responsibilities
Ethics

Knowledge &
Judgment

**Positioning, Field
Coverage, and
Fitness**

Game Management,
Penalty
Administration,
Mechanics

Comportment,
Communication,
Teamwork

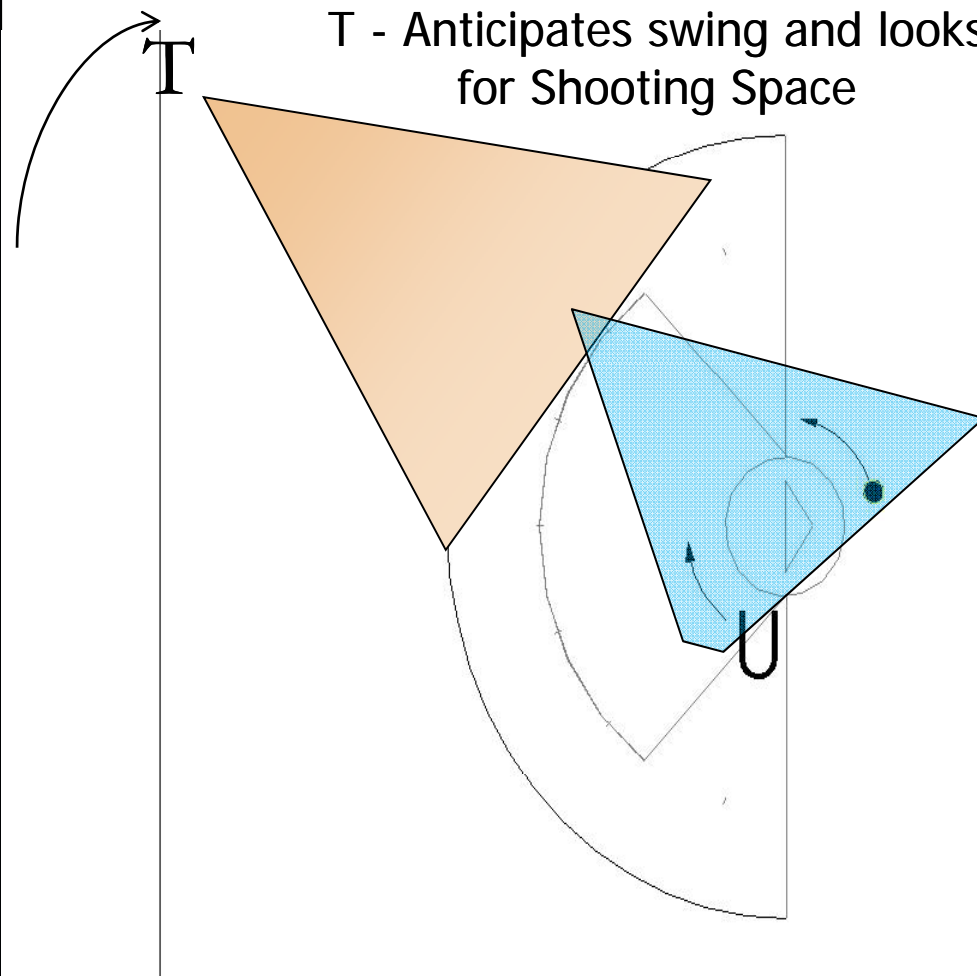

Positioning: Tangent Far Approach

T – FSG, 3 seconds, helps with clearing the penalty lane

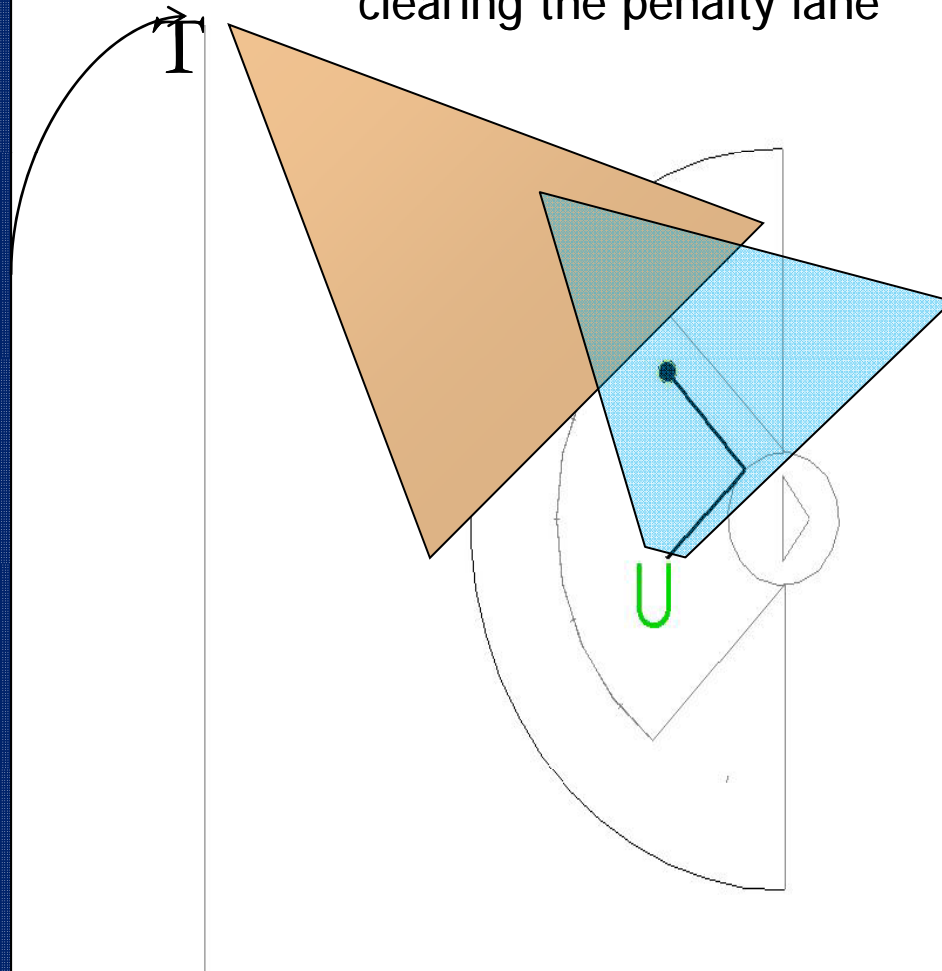

Professionalism,
Responsibilities
Ethics

Knowledge &
Judgment

**Positioning, Field
Coverage, and
Fitness**

Game Management,
Penalty
Administration,
Mechanics

Comportment,
Communication,
Teamwork



Positive Interactions with Coaches

Professionalism,
Responsibilities,
Ethics

Knowledge &
Judgment

Positioning, Field
Coverage, and
Fitness

Game Management,
Penalty
Administration,
Mechanics

Comportment,
Communication,
Teamwork

Professional and respectful

All pregame questions with *both* coaches

Coaches can ask for clarifications at time-outs and halftime

Statements vs. questions

Be patient



Comportment

Professionalism,
Responsibilities
Ethics

Knowledge &
Judgment

Positioning, Field
Coverage, and
Fitness

Game Management,
Penalty
Administration,
Mechanics

Comportment,
Communication,
Teamwork

To elevate one's presence consider:

- Verbal communication
- Non-verbal communication
- Use of "language of the rules"
- Be fit, run into position
- Respect
- Teamwork
- Composure



Comportment

Professionalism,
Responsibilities,
Ethics

Knowledge &
Judgment

Positioning, Field
Coverage, and
Fitness

Game Management,
Penalty
Administration,
Mechanics

Comportment,
Communication,
Teamwork

General professionalism:

- Call a safe, fair game
- The players determine the outcome of the game
- Be approachable, confident, use good judgment
- Appearance, voice, demeanor



Partner Support and Communication

Professionalism,
Responsibilities,
Ethics

Knowledge &
Judgment

Positioning, Field
Coverage, and
Fitness

Game Management,
Penalty
Administration,
Mechanics

Comportment,
Communication,
Teamwork

Posture and demeanor

Non-verbal communication (**arm signals!**) and eye contact

Respect: partner, players, coaches



Professionalism,
Responsibilities ,
Ethics

Knowledge &
Judgment

Positioning, Field
Coverage, and
Fitness

Game Management,
Penalty
Administration ,
Mechanics

Comportment,
Communication,
Teamwork

What comes next...

- Online 2011 Rules Test
 - Link is on our website wwlua.org
 - **Due March 1**
- Field training and rating
 - Junior/Youth Umpires: March 5 – 6
 - Apprentice (Adult) Umpires: March 12



Professionalism,
Responsibilities ,
Ethics

Knowledge &
Judgment

Positioning, Field
Coverage, and
Fitness

Game Management,
Penalty
Administration ,
Mechanics

Comportment,
Communication,
Teamwork

WWLUA Board Position	Umpire Name
Local Board Chair	Maggie O'Sullivan
Chair-Elect	Jeff Grose
Treasurer	Duke Kamstra
Secretary	Jeff Grose
Education Chair	Kareen Kreutziger
Development Chair	<i>Open</i>
NWWLA Liaison	Marisa de la Garza
NWWLA Rating Chair	Janet Lennon-Jones
WSLA HS Liaison	Tsering Short
WSLA HS Rating Chair	Suzanne Replinger
WSLA Youth Liaison	Jared Bryant
WSLA Youth Rating Chair	Edith Harris
At-Large Members	<i>Open</i>

Email addresses are on our website under "Contact Us"

WWLUA Paid Position	Name
WSLA Assignor	Doreen Cronin
NWWLA Assignor	Janet Lennon-Jones
Registrar	Jared Bryant
Bookkeeper	<i>Open</i>



All training materials are new!

Please give us your honest feedback.

Professionalism,
Responsibilities ,
Ethics

Knowledge &
Judgment

Positioning, Field
Coverage, and
Fitness

Game Management,
Penalty
Administration ,
Mechanics

Comportment,
Communication,
Teamwork

**Thank you
for taking part in this
Officials Education Program**

WWLUA

www.wwlua.org

